

# ROLL-OFF TRAILER HOIST TT-OR-176



Tel: 800.285.0666 | sales@wastequip.com  
www.galbreathproducts.com



TT-OR-176 shown with Pioneer Tarping System option

Texas Tongue (TT) roll-off cable hoist trailers are ideal for transporting two container loads safely and effectively. These trailers allow users to haul loads with or without roll off ready trucks. The TT is specifically designed to work integrally with Galbreath's pintle ready aprons, which allow for jack-knifing the trailer for over-the-tongue dumping without having to disconnect.

- » **Tandem axle**
- » **40,000 lb. capacity**

## Standard Features

### Ease of Operation

- Turn lock quick disconnects (hydraulic) for fast hook up and drop off
- Plug n' Play wiring system
- Outside controls positioned in the center of trailer tongue
- Single leg hydraulic landing gear
- ABS braking system

### Safety

- Split bumper w/ LED lighting and back-up alarm
- Fixed ratchet hold downs (2 sets of 2)
- Heavy duty safety stops
- ICC bumper
- Heavy duty rear apron assembly

### Durability

- All pivot joints, roller assemblies & sheave blocks easily accessed for service and grease
- Phosphorus wash before the two-part epoxy primer and paint
- Limited lifetime warranty on frame
- 2 year limited hydraulic system warranty

### Quality

- Lean manufacturing processes
- Engineered with solid modeling to ensure maximum product quality
- Stress analysis testing
- T-1 fabricated tongue
- A500 Grade-C tubing
- 3,000 psi working pressure hoses

## Available Options

- Steel, aluminum or poly fenders
- Pioneer tarping systems
- Auxiliary stops & hold down systems
- Lift axles
- Scale systems
- Tool boxes
- Inside/outside rail (IO-Model)
- Deadlift (HH-Model)
- Extendible tail (EX-Model)
- Special model and option configurations available upon customer request

# ROLL-OFF TRAILER HOISTS TT-OR-176

## Notes for Figure 1 Below:

- 1 When recommending container lengths, weight distribution, fender interference and overhand will all be factors
- 2 Factory tested with recommended container length and water level load
- 3 Use 22.5" tires only; for larger tires, consult representative

A = 143 3/8"	DRAWBAR TO JACK
B = 53"	TANDEM SPREAD
C = 47°	RAISED ANGLE
D = 46"	FRAME HEIGHT
E = 95 1/2"	WIDTH OF TANDEM TIRES
F = 160 3/8"	RAISED HEIGHT
G = 318 9/16"	WHEEL BASE
H = 280 1/8"	HOIST LENGTH
I = 111 1/2"	CENTER OF TANDEM TO END OF HOIST

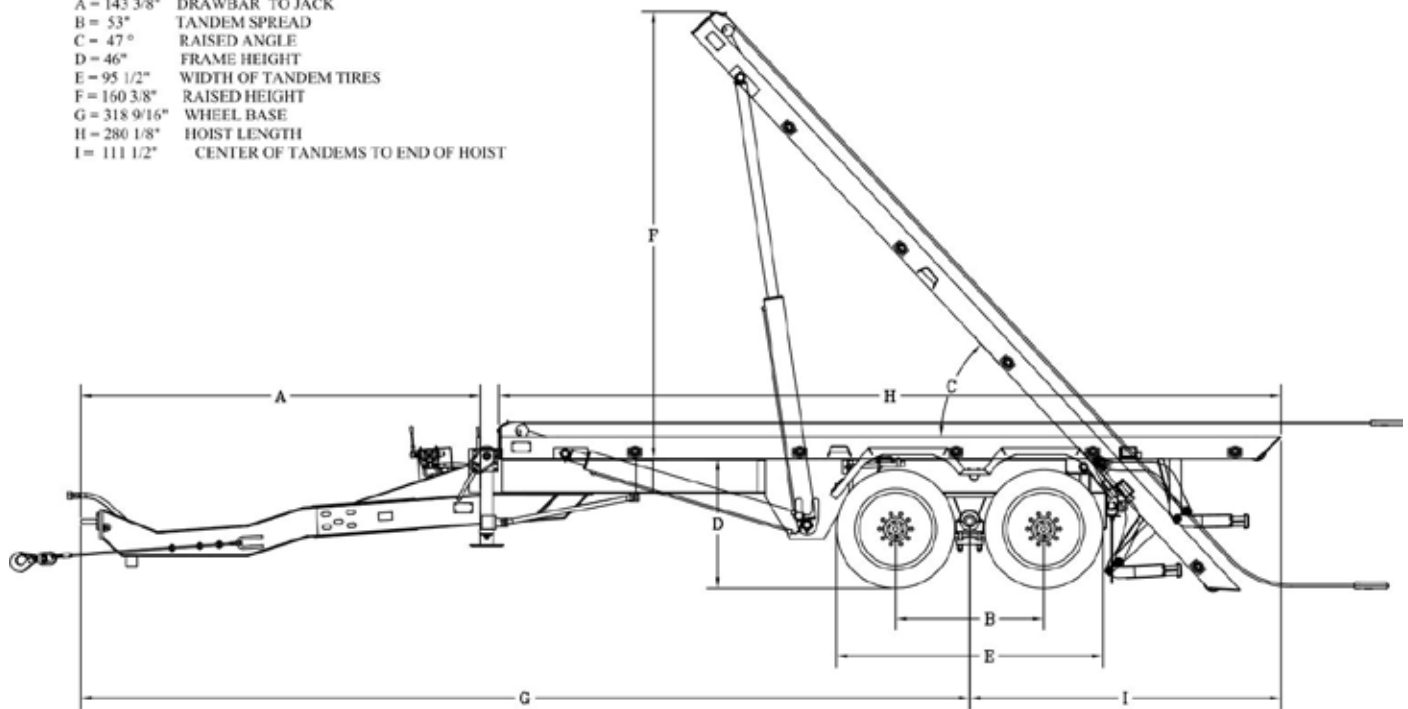

HOIST  
FRAME DETAIL

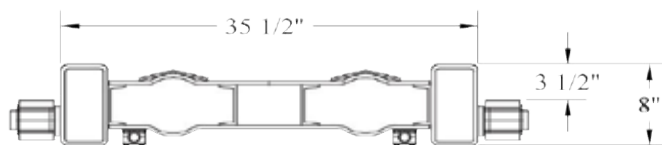

SWIVEL CABLE END

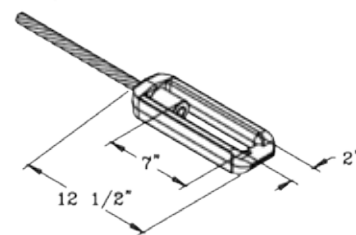

## Minimum Tractor Specifications

Front axle rating 12,000 lbs.

Rear axle rating 44,000 lbs.

50 Gallon reservoir with 50 gpm pump @ 1,500 rpm,  
2,200 psi or greater wet kit capable

Recommended use w/ similar size hoses or larger to match trailer hydraulic system.  
Hoses from tractor need to support the following ends:

1" female quick disconnect (pressure line) connections must be screw type

1 1/4" male quick disconnect (return line) connections must be screw type

FEATURE	TANDEM AXLE
Hoist main frame	8" x 4" x ½" A500 Grade - C tubing (rectangular)
Tail frame	7" x 3" x ½" A500 Grade - C tubing (rectangular)
Bumper	7 gauge manufactured channel with sealed, recessed LED lighting
Front stops	1 ½" steel plate
Front safety lock	Automatic spring loaded (driver's side only, curb side option available)
Hinge shaft	2 ½" solid steel
Cable anchors	4 cable clamps
Cable / cable end	⅞" XIP steel cable / swivel eye cable end 79,600 lbs. test
Cable sheaves	(5) - 10" OD (outside diameter) grease groove with bronze bearings
Working points	Greasable
Outside rollers	4" OD with bronze bearings (5 per side)
Rear hold downs	(2) Sets of 2 ratchet nylon hold downs
Landing gear	140,000 lb. 2-speed single leg
Hydraulic valve	2 - Spool / 45 gpm with safety bypass
System operating pressure	1,850 psi (operating) 2,500 psi (max.)
Lift cylinders	(2) - Dual acting, rod type, forward mount
Winch cylinders (reeving system)	(2) - Dual acting, rod type
Suspension	Hutch single point tandem 50,000 lbs.
Tires and rims	(8) - 11R/22.5 on steel 8.25 x 22.5, 10 hole piloted

## MODEL TT-OR-176

JT - (Jack to Trunion in inches) 176"

Recommended container size <sup>1</sup> (see note above)	18' - 22'	Load angle	47°
Rated hoist capacity <sup>2</sup> (see note above)	40,000 lbs.	D - Frame height <sup>3</sup> (see note above)	46"
- Maximum trailer GVWR	60,000 lbs.	E - Tandem tire width	95 ½"
Lift cylinders	6" x 4" x 72"	F - Raised height	161 11/16"
Lift cylinder hinge pin size	2 ½"	G - Wheelbase	318 9/16"
Winch Cylinders	7" x 4" x 80"	H - Hoist length (total trailer length - add G add I)	280 1/8"
<i>For references below use Figure 1</i>		I - Tandem trunion to tail of hoist	111 ½"
A - Drawbar to Jack	143 3/4"	- Auto fold ICC bumper (standard on OR, IO Models)	Std
B - Tandem spread	53"	Approximate weight with standard features	13,970 lbs.
C - Dump angle	47°		



Tel: 800.285.0666 | [sales@wastequip.com](mailto:sales@wastequip.com)  
[www.galbreathproducts.com](http://www.galbreathproducts.com)



Galbreath is a Wastequip brand. Wastequip is the leading North American manufacturer of waste and recycling equipment for collecting, processing and transporting recyclables and solid or liquid waste.  
© Wastequip 2017 All rights reserved. Specifications subject to improvement without notice. Equipment displayed should be operated by properly trained personnel. Operators should become familiar with OSHA, ANSI and any other applicable standards or laws for using this equipment. Improper use, misuse, or lack of maintenance could cause injury to people and/or property. Photos used in the literature are illustrative only. We assume no liability or responsibility for proper training/operation of equipment not manufactured by Wastequip. We reserve the right to make changes at any time without notice. Information contained within this literature is intended to be the most accurate available at time of printing.

GAL061-032017