

Assorted Cane Lifter Products

Simple operation makes lifting safe and easy

Tough construction for long life

Available in custom height and depth to suit your dumping application

Customized mounting options

UHMW comb and bumpers helps protect carts

Powder-coated finish

Minimal greasing for less maintenance

1-year limited warranty



The AC300 US-type Carriage shown with Cane Track



Canes may be mounted to sidersloaders, roll-off containers, or dockside stands



Perkins

ACCESSORIES | AUTOMATED SYSTEMS | HYDRAULIC LIFTERS | INDUSTRIAL LIFTERS | ACCESSORIES

Perkins Cane-Lifter Product Selection

Cane-type lifters have several unique advantages, such as a straight vertical ascension, tall dumping heights & simple construction. Perkins offers canes in a variety of lengths, with carriages to lift US-type, European type bin, or barrel-grabber style arms! Standard and custom units available.

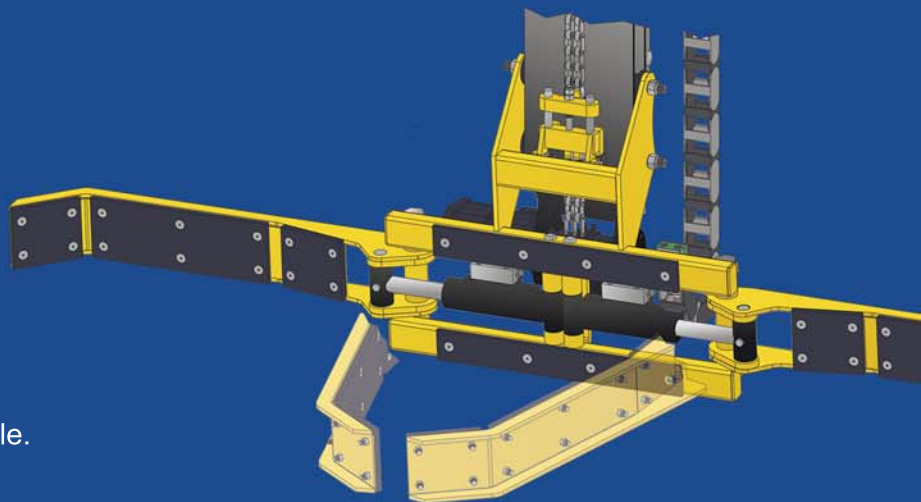

Specifications

- ◆ All grade L9 hardware & 1045 steel construction
- ◆ 3900 in-lbs of torque @ 1200 psi, 500 lb capacity
- ◆ 12 second cycle time @ 10 GPM
- ◆ Chain rated for 9760 lbs
- ◆ 45 degree dump angle
- ◆ Safety Yellow powder-coated finish
- ◆ Plastic bearings at pivot points
- ◆ Easy bolt-on/off mounting
- ◆ 1 year limited warranty

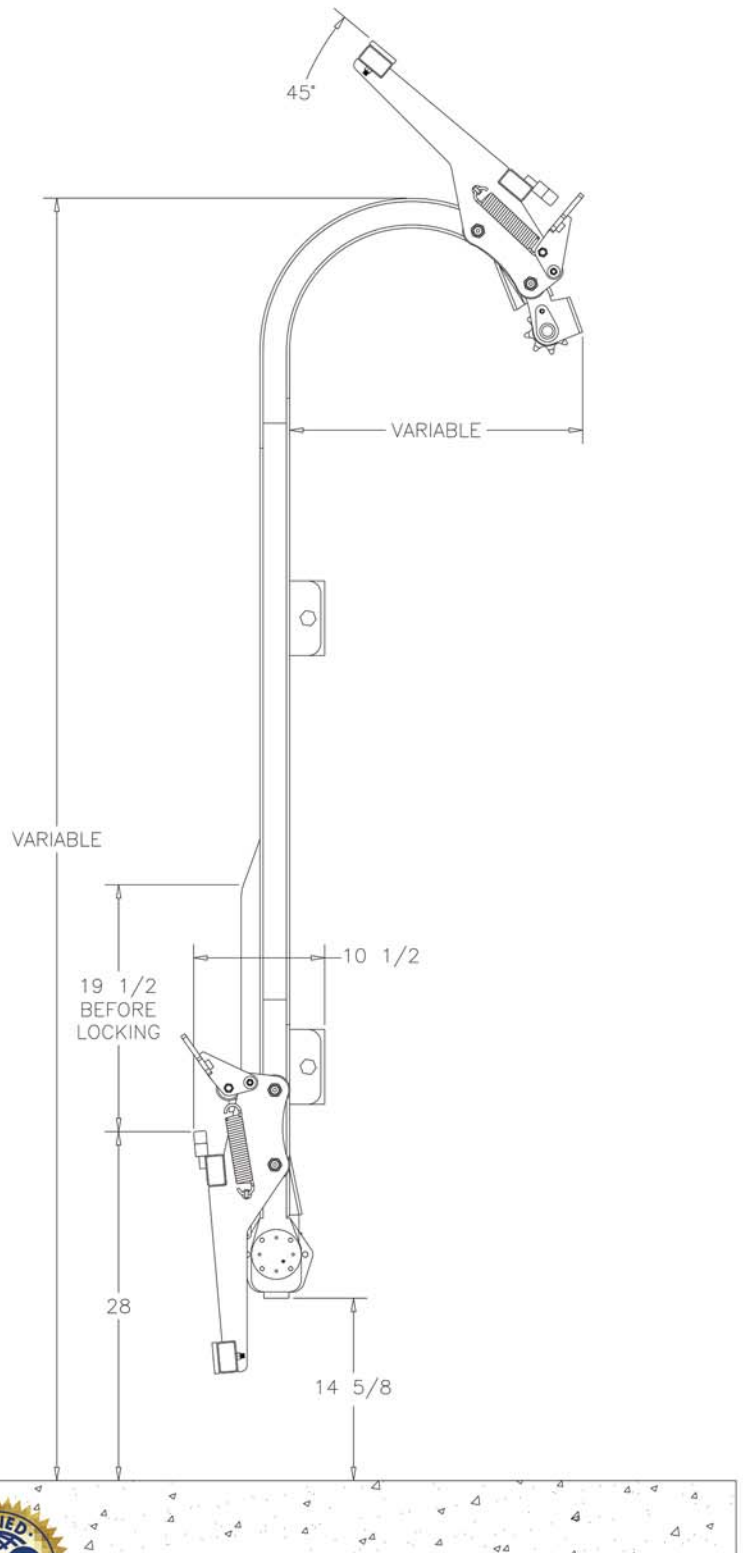

Perkins Manufacturing Company
 737 Oakridge Drive Romeoville, IL 60446
 (708) 482-9500 Fax: (708) 354-5878
 Email: tuckaway@perkinsmfg.com
www.Perkinsmfg.com TOLL FREE 800-882-5292

