

ACCESSORIES | **Perkins** | AUTOMATED SYSTEMS | **HYDRAULIC LIFTERS** | INDUSTRIAL LIFTERS | ACCESSORIES

MODEL D6025b: CYLINDER TIPPER-BAR CART LIFTER

The D6025b offers heavy duty construction combined with a simple cylinder design, ensuring reliable lifts throughout the life of the lifter. The sliding lower latch feature allows this unit to have a high ground clearance. Additional benefits include powder coated finish, plastic upper saddle, and a one year warranty.



The performance you demand requires a serious machine with all the refinements that you've come to expect from the leader in the waste handling industry.

- ◆ Featuring durable modular construction that simplifies repairs
- ◆ Adjustable position saddle and latch allows varied mounting heights
- ◆ Cylinder operated, less expensive and easy to rebuild
- ◆ Designed with few moving parts
- ◆ Plastic bearings and slide requires no grease
- ◆ Plastic hooks handle your carts gently
- ◆ New wider faceplate and latch offers superior cart stability



Specifications

- Fully compatible to ANSI Type B carts
- Mounting height is adjustable at positions 36", 37", 38" & 39"
- 1,000 PSI required for 400lb load
- 6-8 second cycle time @ 3 GPM
- 45 degree dump angle
- Safety Yellow powder-coated finish
- Fiberglide bearings at pivot points
- Easy bolt-on/off mounting plate included
- UHMW upper saddle
- Adjustable flow control valve
- 1 year limited warranty

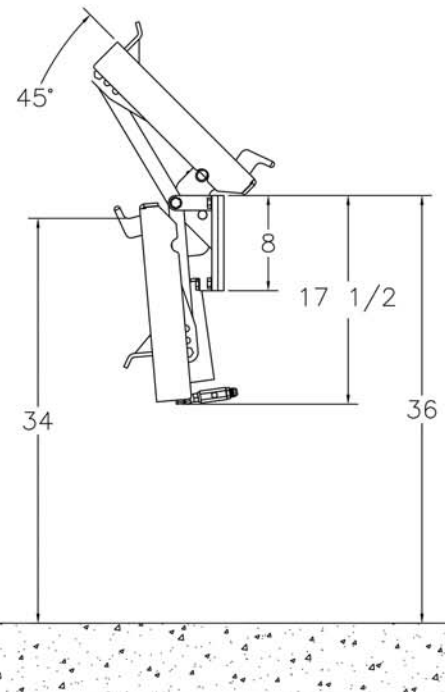
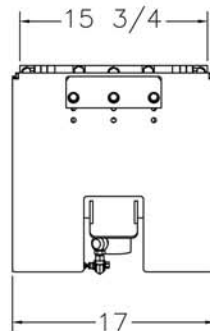

Perkins Manufacturing Company

737 Oakridge Drive Romeoville, IL 60446

(708) 482-9500 Fax: (708) 354-5878

Email: tuckaway@perkinsmfg.com

www.Perkinsmfg.com TOLL FREE 800-882-5292

