

APARTMENT STYLE COMPACTORS



Mini-M.A.C.®

Apartment Compactor

The **Mini-M.A.C.** apartment compactor is a small, yet powerful compactor that can fit in areas where space is limited, such as trash rooms of apartment and high-rise buildings. It is commonly used in conjunction with a chute feed system in multi-storied buildings.



Mini-M.A.C.® Features

- ▼ *4:1 compaction ratio over un-compacted waste receptacles*
- ▼ *Remote power unit*
- ▼ *Convenient single-side ratchet*
- ▼ *Push-button controls mounted in the panel box face*
- ▼ *Hopper with access door and interlock for hand-feed or chute-feed applications*
- ▼ *Photoelectric cycle control*
- ▼ *Full container light*
- ▼ *CYCON Life-Xtender™ Cyclic Control System that offers reliable, solid-state circuitry eliminating pressure and limit switches*



APARTMENT STYLE COMPACTORS



Mini-M.A.C.®

Dimensions and Specifications

Specifications	Model 3A/3 hp		Model 5A/5 hp	
	Clear Top Opening	22.5" L x 28" W	572 mm x 711 mm	22.5" L x 28" W
Capacity Per Hour	37 yd ³	28 m ³	74 yd ³	57 m ³
Performance Characteristics				
Cycle Time	21 sec.		14 sec.	
Normal Force	13,900 lbs.	6305 kg	13,900 lbs.	6305 kg
Pack-Out Force	16,400 lbs.	7439 kg	16,400 lbs.	7439 kg
Normal Ram Face Force	23.2 psi	160 kPa	23.2 psi	160k Pa
Pack-Out Ram Face Force	27.3 psi	188 kPa	27.3 psi	188k Pa
Ram Penetration	4"	102 mm	4"	102 mm
Weight	1,600 lbs.	726 kg	1,600 lbs.	726 kg
Electrical Equipment				
Tri-Volt Motor 208/230/460	3 hp	2.2 kW	5 hp	3.7 kW
Electric Control Voltage	120 VAC			
Remote power unit with controls mounted in the face of the box NEMA 3-type, All circuits fused Standard controls: Keylock start/stop/reverse				
Hydraulic Equipment				
Hydraulic Pump Capacity	4 gpm	15.1 L/min	6 gpm	22.7 L/min
Normal System Pressure	1,650 psi	112 bar	1,650 psi	112 bar
Maximum System Pressure	1,950 psi	134 bar	1,950 psi	134 bar
Hydraulic Cylinders (2) Bore	2.5"	64 mm	2.5"	64 mm
Hydraulic Cylinder (2) Rod	1.25"	32 mm	1.25"	32 mm

Additional Features of the 3A & 5A Models: Standard Chute Feed Hopper with (left hand or right hand) Access Door & Interlock; Photocell Package which includes Start-Up Alarm; Advanced Warning; Container Full; and Auto Shut-down.

Pictures and mechanical diagrams in this literature are illustrative only and may not be to scale. Specifications are subject to change without notice in order to accommodate improvements to the equipment. Certified in compliance with ANSI standard Z245.2, all applicable OSHA Regulations. Products must be used only by trained operators in accordance with the Operator Manual, as well as applicable regulations, laws, and ANSI standards.

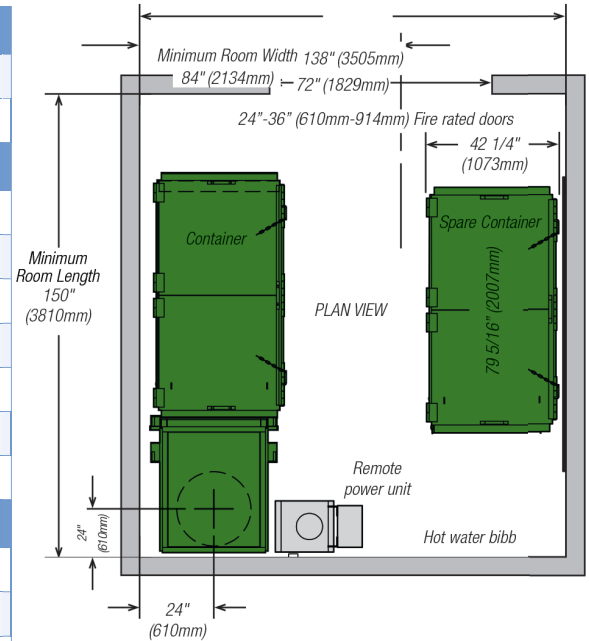

Typical Mini-M.A.C. Model 3A compactor configuration with chute system

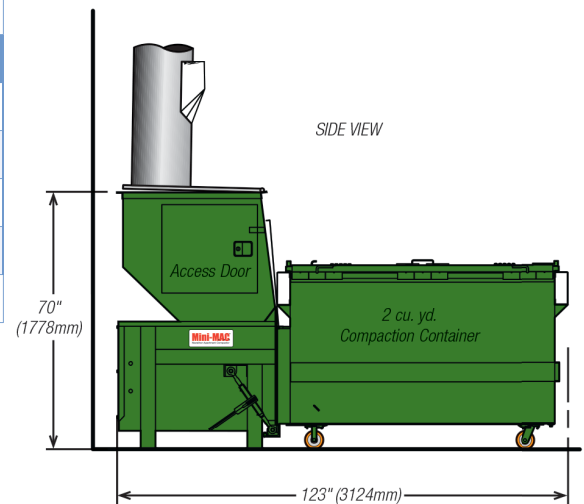

For detailed specifications, recommendations, or free economic studies comparing various systems, contact Marathon® Customer Care at **1-800-633-8974**

Authorized Dealer:

Compactor & Baler Rental and Leasing Programs Available!



Marathon Equipment Company | P.O. Box 1798 | Vernon, AL 35592-1798

Learn more about Marathon Equipment: 800.633.8974 | www.marthonequipment.com